





# EQUINE VETERINARY EDUCATION



 **EQUINE VETERINARY EDUCATION**  
American Edition | September 2022



 **BEVA**  
The official journal of the  
Board of Equine Veterinary Association  
of Practitioners and Owners  
in partnership with AAEP.

**IN THIS ISSUE:**

From the president: Learn it all on the track  
Advancing the management of bilateral mandibular condylar cysts and associated  
sequelae of the temporomandibular joints in a horse  
Typical follow-up as an adjunct treatment in equine  
otitis media with effusion and otitis externa



**Media Kit  
2023**

## Reader Profile

### Gender

Female	55%
Male	45%

### Audience

Nearly 9,000 veterinarians and veterinary students responsible for equine healthcare decisions.

### AAEP Members

United States	6,810
Canada	477
International	413
Students	1,114

### Focus of Equine Practice

Performance	34%
Pleasure/Farm	30%
Reproduction	10%
Racing	10%
Work/Ranch	4%
Other	6%

### Top 3 Roles in Practice

Owner/Sole Proprietor	36%
Associate	22%
Owner/Partnership	14%

### Age

Over 60 years	31%
40-59 years	35%
Under 40 years	34%

### Years a Member (loyalty)

50+ years	3%
40-49 years	6%
30-39 years	14%
20-29 years	15%
10-19 years	28%
Under 10 years	34%

### Non-Equine Work

Birds	5%
Bovine	28%
Companion	30%
Exotic	6%
Small Ruminants	28%
Swine	14%

## About the American Association of Equine Practitioners



The American Association of Equine Practitioners, headquartered in Lexington, Ky., was founded in 1954 as a non-profit organization dedicated to the health and welfare of the horse. Currently, the AAEP reaches more than 5 million horse owners through its nearly 9,000 members worldwide and is actively involved in ethics issues, practice management, research and continuing education in the equine veterinary profession and horse industry.

## About Equine Veterinary Education

*Equine Veterinary Education (EVE)* provides peer-reviewed educational articles that assist equine veterinarians in the diagnosis and treatment options of a broad range of conditions affecting horses and other equids. The journal is mailed each month on the 15th to approximately 7,000 domestic and international licensed veterinarians.



## Why should your company advertise in EVE?

Equine veterinarians are the primary authorities for health care decisions affecting horses. By advertising in *EVE*, your company gains exposure to the most trusted veterinary professionals in the equine industry – AAEP members. You will reach a highly desirable audience to promote equine health care products and services.

As an added benefit and at no additional cost, your ad will also appear in the digital version of *EVE* available on the AAEP website and in our members-only *AAEP Publications App*. Ad will link directly to your website if a URL is included within the ad.



## Advertising Rates

Space is limited and granted on a first-come basis. All rates are net.

Full Color	1x	3x	6x	12x
Full Page	\$1,800	\$1,700	\$1,600	\$1,500
1/2 Page	\$1,000	\$950	\$850	\$750
Inside Cover	\$2,000	\$1,800	NA	NA
Outside Back Cover	\$2,250	\$1,950	NA	NA
2-Page Spread	\$2,200	\$2,000	\$1,700	NA

### Disclaimers/Legals (B/W)

1/3 Page Horz.	\$250	1/2 Page Horz.	\$425	Full Page	\$650
----------------	-------	----------------	-------	-----------	-------

### Belly Band

Full color belly bands are available to advertisers during selective months. For details on rates and technical specifications, please contact Dana Kirkland at [dkirkland@aaep.org](mailto:dkirkland@aaep.org)

## Advertisement and Printing Specifications

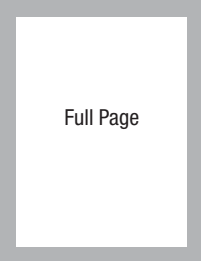
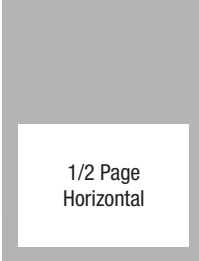
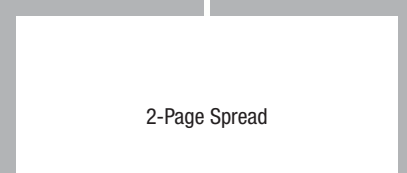
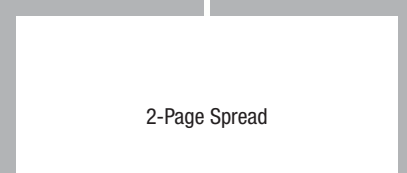
	Width	Height	
Full Page:			
Trim	8.125"	10.875"	
Bleed	8.375"	11.125"	
<b>Live area</b>	<b>7"</b>	<b>10"</b>	
2-Page Spread:			
Trim	16.25"	10.875"	
Bleed	16.5"	11.125"	
<b>Live area</b>	<b>15.125"</b>	<b>10"</b>	
(allow 1.125" for gutter)			
1/2 Page	6.75"	4.5"	
1/3 Page Disclaimer	6.5"	3"	

For full bleed, allow 1/8" on each side, top and bottom. Text for bleed pages should not exceed the live area.

## Ad File Specifications

All ads must be submitted in an electronic format. Ad files should be 300 DPI at 100% size and set for CMYK output. The preferred file format is press-quality PDF. Other acceptable formats include InDesign, Illustrator or Photoshop files. All fonts and graphic support files used in the ad must be included, or properly embedded. Avoid submitting JPEGs due to the potential for loss of quality and unexpected results upon output.

# AAEP marketplace



### Ad Rates for Marketplace Ads

Equine Veterinary Education's Marketplace section provides quarter-page ads in issues from June to November. This special section must be purchased as a package of six insertions to appear one time in each of the specified issues. Issues prior to the AAEP's Annual Convention will include Trade Show booth numbers in the advertisers' index. The package rate is \$1,500; no discounts will be offered. Marketplace ads will be billed in August.

### Specifications for Marketplace Ads

	WIDTH	HEIGHT
1/4 PAGE	3.25"	4.5"

Also see Ad File Specifications below.

Ads may be changed, up to three times per the 6-month period, for an additional \$100 per ad change.

## 2023 Advertising Schedule

Issue Month	Ads Due
January	Dec. 2 (2022)
February	Jan. 2
March	Feb. 2
April	Mar. 2
May	Apr. 3
June	May 2
July	June 2
August	July 3
September	Aug. 2
October	Sept. 1
November	Oct. 2
December	Nov. 2

Target mailing date is the 15th of the publication month.

# Advertising Contract Agreement

Date: \_\_\_\_\_

Advertiser: \_\_\_\_\_

Frequency: \_\_\_\_\_

Contact: \_\_\_\_\_

Insertion Dates:

- January  February  March  
 April  May  June  
 July  August  September  
 October  November  December

Billing Address: \_\_\_\_\_

City: \_\_\_\_\_ State: \_\_\_\_\_ Zip: \_\_\_\_\_

- Full Color  Black & White

Phone: \_\_\_\_\_ Fax: \_\_\_\_\_

Size:  Full Page  1/2 Page

Email: \_\_\_\_\_

2-Page Spread

1/4 Page (*Marketplace insertion only*)

Full Page (*disclaimer/legal*)

1/2 Page (*disclaimer/legal*)

1/3 Page (*disclaimer/legal*)

Advertiser agrees to the Terms & Conditions below.

Rate: \_\_\_\_\_

\_\_\_\_\_  
Authorized Signature for Advertiser

\_\_\_\_\_  
Print Name Here

Copy/Material: Due 1st of month  
preceding publication

\_\_\_\_\_  
Accepted by Dana Kirkland  
*Sponsorship & Advertising Coordinator*

## Terms & Conditions

1. Accepted subject to provisions of current Rate Card and General Copy and Contract Regulations.
2. Cancellation or curtailment of space reservation will result in short rate adjustment. A signed contract must be submitted before any advertisement will be published. Cancellations must be in writing and received 30 days prior to cover date. If the cancellation is not received in this timely manner, the client will still be invoiced at the applicable rate.
3. Rates are subject to change upon notice from the Publisher. Rate protection is extended to advertisers with signed contracts specifying insertion dates.
4. Advertisers must be current AAEP exhibitors unless otherwise specified.

Terms for invoicing are net 30 days after advertisement has published.

All companies wishing to advertise in *Equine Veterinary Education, American edition*, must be current AAEP exhibitors. AAEP retains the right, in its sole discretion, to determine the circumstances under which an exhibitor may advertise in this journal. While all advertisers must comply with applicable legal guidelines, Compounding Pharmacies are specifically directed to limit themselves to pharmacy practices as dictated by the FDA Center for Veterinary Medicine, Compliance Policy Guideline (<https://tinyurl.com/fdacvmcpg>). Advertising any complete or partial mimicry of drugs and dosage forms of FDA-approved formulations will not be accepted. Compounding Pharmacies, or any other exhibitors/advertisers who violate this rule in any fashion, will render their advertising contract null and void.

*As a private organization, the AAEP reserves the right to exclude any company from advertising in Equine Veterinary Education, American edition, for any reason. The signing and delivery of the advertising contract shall constitute an offer subject to acceptance by the AAEP. In its sole and absolute discretion, AAEP may revoke its acceptance of the advertising contract or may terminate any contract by delivery of written notice, in which event the AAEP shall have no liability to the advertiser for damages or any other remedy.*



For further information or to purchase advertising space, please contact:

Dana Kirkland, Sponsorship & Advertising Coordinator

American Association of Equine Practitioners

dkirkland@aaep.org | (859) 233-0147

**4033 Iron Works Parkway | Lexington, KY 40511**